

# Check valve

## Spring loaded check

$Q_{\max} = 25 \text{ l/min}$ ,  $p_{\max} = 350 \text{ bar}$

plate type

Type series: RVC-06-...

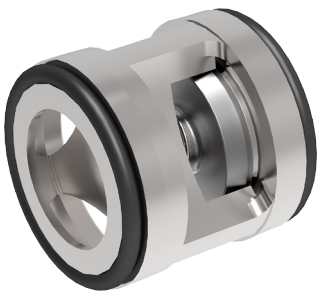

- Slip-in cartridge valve
- Can be used as a screw-in valve in conjunction with an ESH threaded mounting sleeve
- Exceptionally high  $Q_{\max}$  with extremely low  $\Delta p$
- No-flow direction can be reversed
- Virtually leak-proof in closed condition
- Optional metered flow in the no-flow direction
- Particularly suitable for use as a make-up check valve

### Description

The RVC series plate-type check valve is characterized by very high pressure load capacity and extremely low  $\Delta p$ . The no-flow direction can be reversed by inverting the valve in its cavity. The slip-in cartridge valve RVC can be used in conjunction with an ESH threaded mounting sleeve like a screw-in valve. Due to its fast response, it can be used as a make-up check valve. Orifices in the valve plate allow simple "metered check"

functions. The spring-loaded poppet-type check valve in plate design is very robust, extremely leak-proof and insensitive to contamination. Valve seat, poppet and body are hardened. The properties of the sealing faces have been enhanced by precision mechanical processing. The valve is available in nominal sizes 04, 06, 08, 10, 16 and 25.

### Symbol

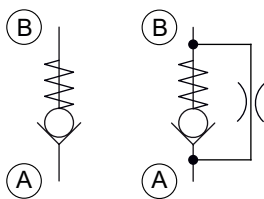

Technical Data

General Characteristics	Description, value, unit
Function group	Check valve
Function	Spring loaded check
Design	Slip-in cartridge valve
Characteristic	plate type
Construction size	nominal size 06
Mounting attitude	unrestricted
Weight	0.007 kg

Hydraulic Characteristics	Description, value, unit
Maximum operating pressure	350 bar
Maximum flow rate	25 l/min
Nominal flow rate	15 l/min
Flow direction	see symbol
Hydraulic fluid	HL and HLP mineral oil according to DIN 51 524; other fluids on request!
Minimum fluid temperature	- 30 °C
Maximum fluid temperature	+ 80 °C
Viscosity range	10 ... 500 mm <sup>2</sup> /s (cSt)
Minimum fluid cleanliness (cleanliness class according to ISO 4406:1999)	class 20/18/15
Opening pressure	0.2..0.3 / 1.0 / 2.0 bar

**i** **NOTE!**  
For other values please contact Bucher Hydraulics.

Performance graphs

measured with oil viscosity 33.0 mm<sup>2</sup>/s (cSt)

$\Delta p = f(Q)$  Pressure drop-flow rate characteristic

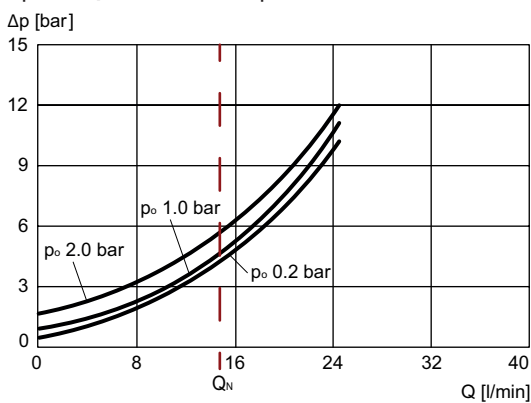

Dimensions and sectional view

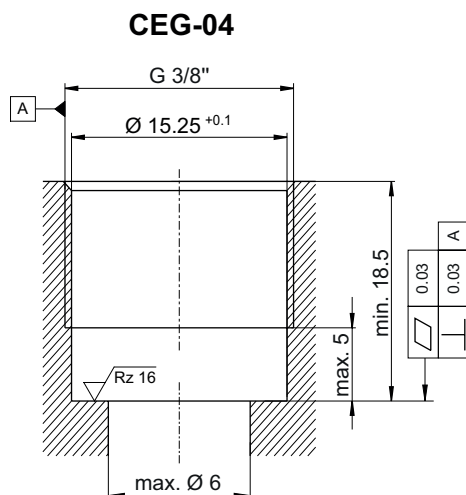
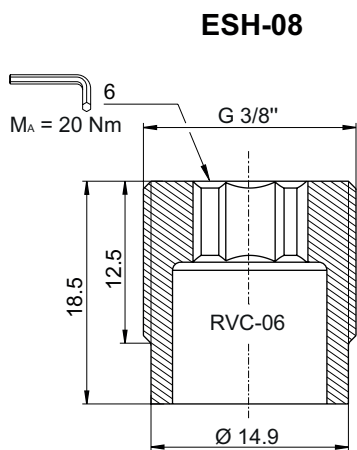
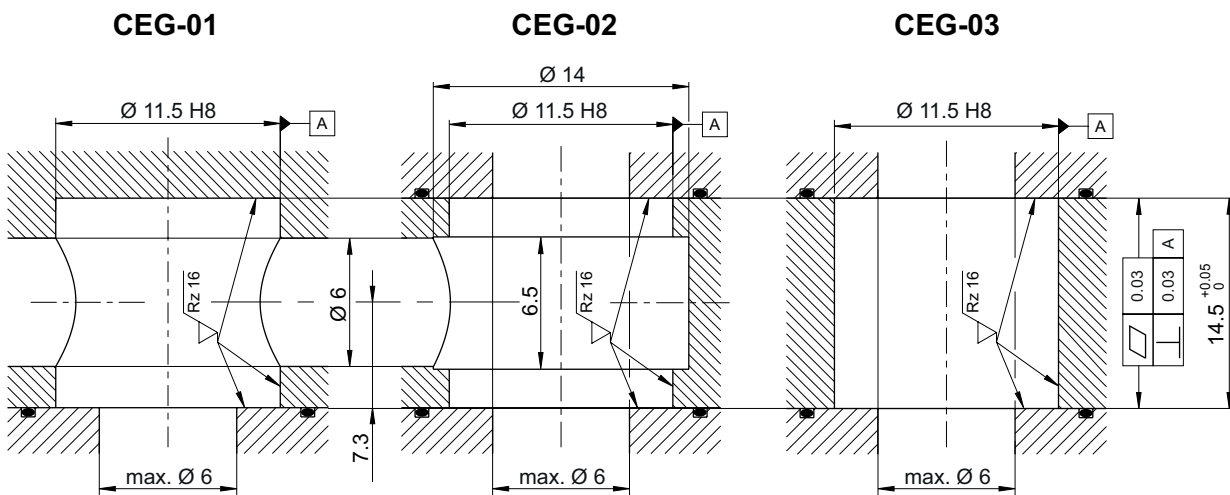
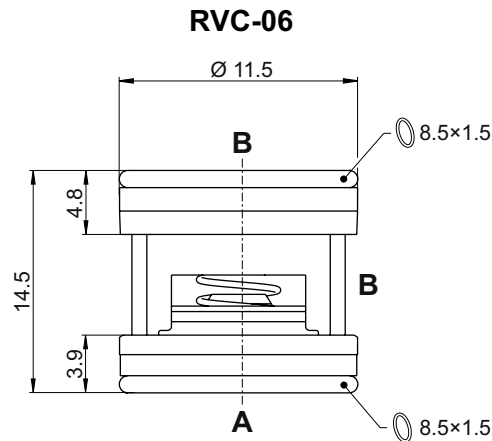

**RVC-06** = spring-loaded check valve / slip-in cartridge valve

**CEG-01, CEG-02 and CEG-03** = dimension of the cavity for screw-in cartridge RVC-06

**ESH-08** = threaded mounting sleeve for RVC-06

**CEG-04** = dimension of the cavity for threaded mounting sleeve ESH-08

## Installation information



### NOTE!

The tightening torque must be observed, when installing with a threaded mounting sleeve ESH. The value can be found in the chapter dimensions and sectional view. Orifices or nozzles are to be placed after the check valve. If this is not possible, a right-angled bore must be designated between the check valve and the nozzle. (see data sheet 170-P-059000). Recommendation: before installing the valve, fit the O-ring in the cavity.



### ATTENTION!

It must be ensured that the valve is firmly seated on the sealing surface during installation and does not protrude beyond the installation space or exceed the tolerance H.

## Application Notes



### NOTE!

The maximum operating pressure must not be exceeded even when pressure peaks occur. In applications such as accumulator circuits, where sudden pressure can be applied to the valve in the free-flow direction, ensure that the specified flow ratings are not exceeded. Buyers bear the sole responsibility for ensuring that the valve is suitable for their applications and must be substantiated by trials or testing, if necessary.



### ATTENTION!

The valves are only suitable for pressure relief in the opening direction to a limited extent. (if necessary, please consult Bucher Hydraulics).

## Ordering code

Ex. RVC - 06 - 03 - D10 - \_

- RVC = check valve, plate design, slip-in cartridge valve
- 06 = nominal size 06,  $Q_{Nominal}$  15 l/min
- 03 = opening pressure 0.2 up to 0.3 bar
- 1 = opening pressure 1.0 bar
- 2 = opening pressure 2.0 bar
- (blank) = no orifice bore
- D04 = orifice bore with diameter 0.4 mm
- D05 = orifice bore with diameter 0.5 mm
- D06 = orifice bore with diameter 0.6 mm
- D08 = orifice bore with diameter 0.8 mm
- D10 = orifice bore with diameter 1.0 mm
- D12 = orifice bore with diameter 1.2 mm
- D15 = orifice bore with diameter 1.5 mm
- D20 = orifice bore with diameter 2.0 mm
- D25 = orifice bore with diameter 2.5 mm
- (blank) = NBR (nitril-butadien-rubber / BUNA) seals (*standard*)
- V = FKM (fluorocarbon rubber / VITON) seals

## Related data sheets

Reference	Description
170-P-059000	Using nozzles or orifices before a Check Valve