

Check valve

Spring loaded check

$Q_{\max} = 200 \text{ l/min}$, $p_{\max} = 350 \text{ bar}$

ball type

Type series: RKVC-25-...

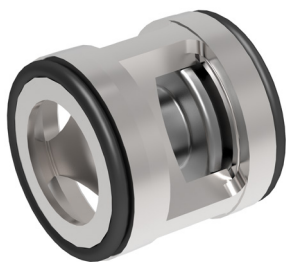

- Slip-in cartridge valve
- Exceptionally high Q_{\max} with extremely low Δp
- Virtually leak-proof in closed condition
- No-flow direction can be reversed
- Can be used as a screw-in valve in conjunction with an ESH threaded mounting sleeve
- Can be used as right-angle valve

Description

The RKVC series spherical poppet-type check valve is characterized by very high pressure load capacity and extremely low Δp . The no-flow direction can be reversed by inverting the valve cartridge in its cavity. The push-in RKVC cartridge valve can be used in conjunction with an ESH threaded mounting sleeve like a screw-in valve. The spring-loaded poppet-type check

valve very robust, extremely leak-proof and insensitive to contamination. Valve seat, poppet and body are hardened. The properties of the sealing faces have been enhanced by precision mechanical processing. The valve is available in nominal sizes 04, 06, 08, 10, 16, 25, 32 and 40.

Symbol



Technical Data

General Characteristics	Description, value, unit
Function group	Check valve
Function	Spring loaded check
Design	Slip-in cartridge valve
Characteristic	ball type
Construction size	nominal size 25
Mounting attitude	unrestricted
Weight	0,08 kg

Hydraulic Characteristics	Description, value, unit
Maximum operating pressure	350 bar
Maximum flow rate	200 l/min
Nominal flow rate	140 l/min
Flow direction	see symbol
Minimum fluid temperature	- 30 °C
Maximum fluid temperature	+ 80 °C
Viscosity range	10 ... 500 mm ² /s (cSt)
Minimum fluid cleanliness (cleanliness class according to ISO 4406:1999)	class 20/18/15
Opening pressure	0,2 / 0,5 / 1 / 2 bar

i NOTE!
For other values please contact Bucher Hydraulics.

Performance graphs

measured with oil viscosity 33.0 mm²/s (cSt)

$\Delta p = f(Q)$ Pressure drop-flow rate characteristic

Δp [bar]

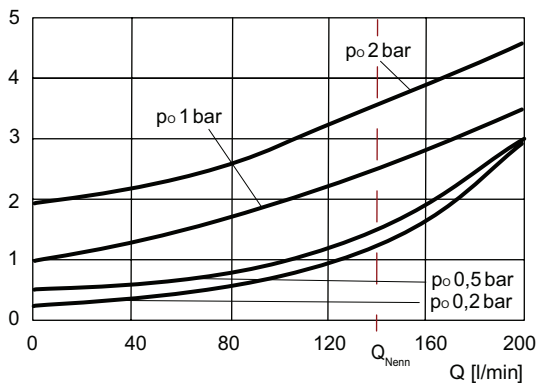

Dimensions and sectional view

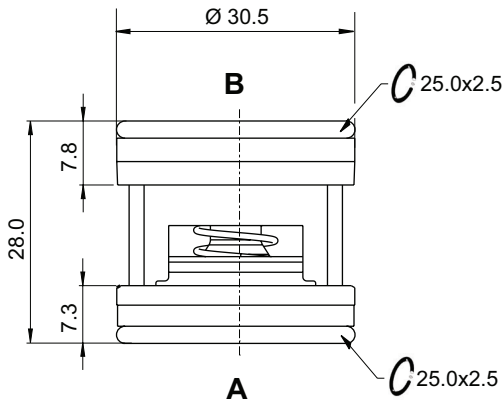

CEG-01

CEG-02

CEG-03

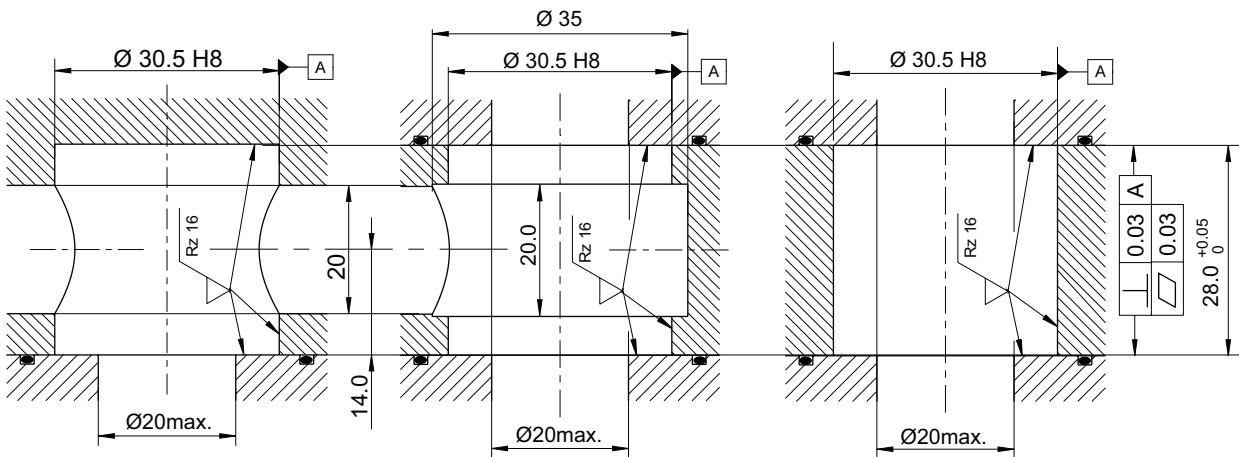

ESH-32

CEG-04

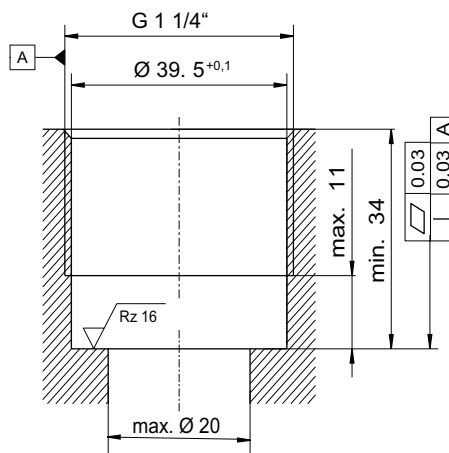
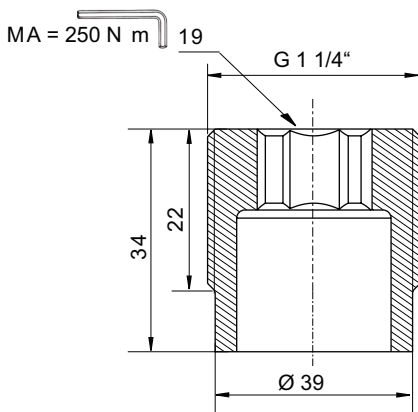

RKVC-25 = spring-loaded check valve / slip-in cartridge valve

CEG-01, CEG-02 and CEG-03 = dimension of the cavity for screw-in cartridge RKVC-25

ESH-32 = threaded mounting sleeve for RKVC-25

CEG-04 = dimension of the cavity for threaded mounting sleeve ESH-32

Installation information



IMPORTANT!

The tightening torque must be observed, when installing with a threaded mounting sleeve ESH. The value can be found in the chapter dimensions and sectional view. Orifices or nozzles are to be placed after the check valve. If this is not possible, a right-angled bore must be designated between the check valve and the nozzle. (see data sheet 170-P-059000). Recommendation: before installing the valve, fit the O-ring in the cavity.



ATTENTION!

It must be ensured that the valve is firmly seated on the sealing surface during installation and does not protrude beyond the installation space or exceed the tolerance H.

Application Note



NOTE!

The maximum operating pressure must not be exceeded even when pressure peaks occur. In applications such as accumulator circuits, where sudden pressure can be applied to the valve in the free-flow direction, ensure that the specified flow ratings are not exceeded. Buyers bear the sole responsibility for ensuring that the valve is suitable for their applications and must be substantiated by trials or testing, if necessary.



ATTENTION!

The valves are only suitable for pressure relief in the opening direction to a limited extent. (if necessary, please consult Bucher Hydraulics).

Ordering code

RKVC - 25 - 05 -

RKVC = check valve, push_in type, spherical poppet

25 = nominal size 25, $Q_{Nominal}$ 140l/min

02 = opening pressure 0,2 bar

05 = opening pressure 0,5 bar

1 = opening pressure 1 bar

2 = opening pressure 2 bar

blank = NBR (Nitrile) seal (standard)

V = FKM (Viton) seal

Related data sheets

Reference	Description
170-P-059000	Using nozzles or orifices before a Check Valve