

# Inverse Proportional Pressure-Reducing Cart., Size 10

$Q_{\max} = 120 \text{ l/min}$ ,  $p_{\max} = 300 \text{ bar}$   
Seated pilot, spool-type main stage  
Series DRPSA-5DG...

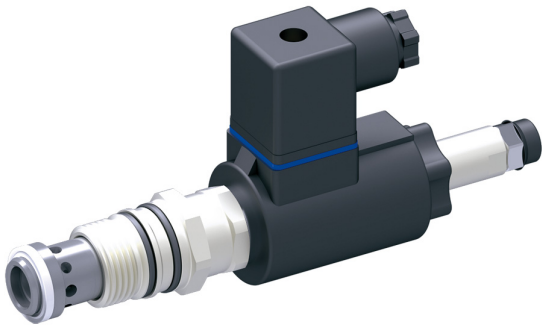

- Compact construction for cavity type DD – M24 x 1.5
- Nominal pressure when solenoid de-energised (fail-safe function)
- 5 pressure ranges available
- All exposed parts with zinc-nickel plating
- High pressure wet-armature solenoids
- The slip-on coil can be rotated, and it can be replaced without opening the hydraulic envelope
- Various plug-connector systems and voltages are available
- With integral manual pressure setting
- Can be fitted in a line-mounting body

## 1 Description

Series DRPSA-5DG... inverse-proportional pressure-reducing valves are size 10, high performance, two stage screw-in cartridges with an M24 x 1.5 mounting thread. They consist of a spool-type main stage and a leak-free, poppet-type pilot stage with a falling pressure/current characteristic. With these proportional pressure-reducing cartridges, the outlet pressure in A is dependent on the electrical control current and can be continuously varied. When the solenoid is de-energised (initial position), the effective pressure is the nominal pressure of the applicable pressure range (fail-safe function). In control mode, the reduced pressure is inversely proportional to the change in the required value (amplifier output current). In order to obtain precise pressure settings over the whole of the required pressure range (optimum resolution), the

pressure-reducing cartridges are available in five spring ranges. To achieve a high degree of functional stability in systems that are susceptible to oscillation, the pilot drain (port Z) must be routed to tank with the least possible back-pressure. These inverse-proportional pressure-reducing cartridges are predominantly used in mobile and industrial applications for reducing a system pressure. All external parts of the cartridge are zinc-nickel plated to DIN 50 979 and are thus suitable for use in the harshest operating environments. The slip-on coils can be replaced without opening the hydraulic envelope and can be positioned at any angle through 360°. If you intend to manufacture your own cavities or are designing a line-mounting installation, please refer to the section "Related data sheets".

## 2 Symbol

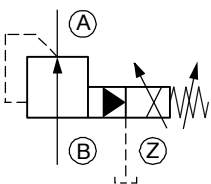

## 3 Technical data

General characteristics	Description, value, unit
Designation	inverse proportional pressure-relief cartridge
Design	seated pilot, spool-type main stage
Mounting method	screw-in cartridge M24 x 1.5
Tightening torque	can be fitted in steel 65 Nm ± 10 % can be fitted in aluminium 50 Nm ± 10 %
Size	nominal size 10, cavity type DD

General characteristics	Description, value, unit
Weight	0.60 kg
Mounting attitude	unrestricted (preferably vertical, coil down)
Ambient temperature range	-25 °C ... +50 °C

Hydraulic characteristics	Description, value, unit
Maximum operating pressure ( $p_{max}$ ) - main port A and B - port Z	300 bar no back-pressure
Maximum flow rate	120 l/min
Nominal pressure ranges ( $p_N$ )	50 bar, 100 bar, 160 bar, 230 bar, 300 bar
Pilot-oil consumption	0.1 ... 0.4 l/min
Flow direction	B → A, see symbols
Hydraulic fluid	HL and HLP mineral oil to DIN 51 524; for other fluids, please contact BUCHER
Hydraulic fluid temperature range	-25 °C ... +70 °C
Viscosity range	15...380 mm <sup>2</sup> /s (cSt), recommended 20...130 mm <sup>2</sup> /s (cSt)
Minimum fluid cleanliness Cleanliness class to ISO 4406 : 1999	class 18/16/13

Electrical characteristics	Description, value, unit
Supply voltage	12 V DC, 24 V DC
Control current	12 V = 0...1400 mA, 24 V = 0...750 mA
Power consumption at max. control current	max. 19 W
Coil resistance R - cold value at 20 °C - max. warm value	12 V = 5.8 Ω / 24 V = 20.9 Ω 12 V = 9.1 Ω / 24 V = 32.7 Ω
Recommended PWM frequency (dither)	200 Hz
Hysteresis with PWM	2...4 % $I_N$
Reversal error with PWM	2...4 % $I_N$
Sensitivity with PWM	< 1 % $I_N$
Reproducibility with PWM	< 2 % $p_N$
Relative duty cycle	100 %
Protection class to ISO 20 653 / EN 60 529	IP 65 / IP 67 / IP 69K, see "Ordering code" (with appropriate mating connector and proper fitting and sealing)
Electrical connection	DIN EN 175301-803, 3-pin 2 P+E (standard) for other connectors, see "Ordering code"

## 4 Performance graphs measured with oil viscosity 33 mm<sup>2</sup>/s (cSt)

$p = f(I)$  Pressure adjustment characteristic

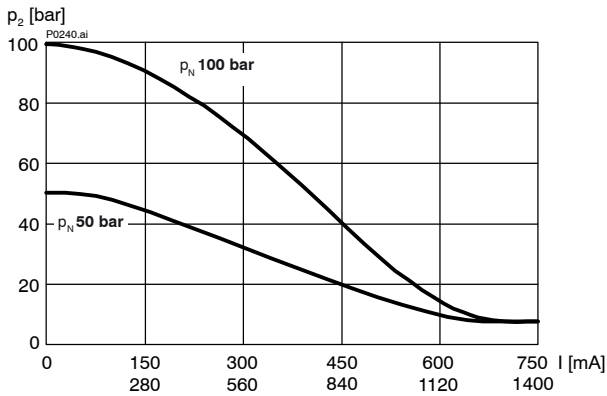

$p = f(I)$  Pressure adjustment characteristic

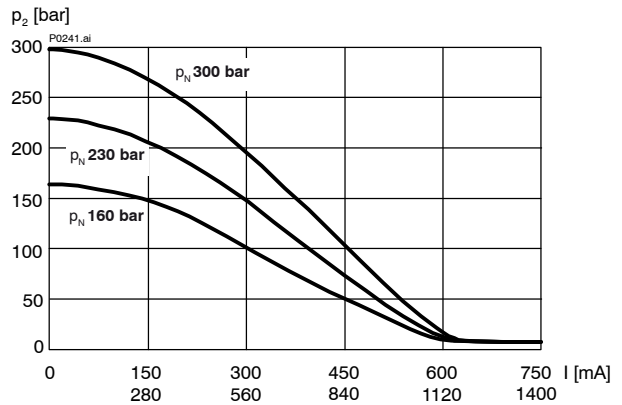

$p = f(Q)$  Pressure - Flow rate characteristic  $p_N = 50$  bar

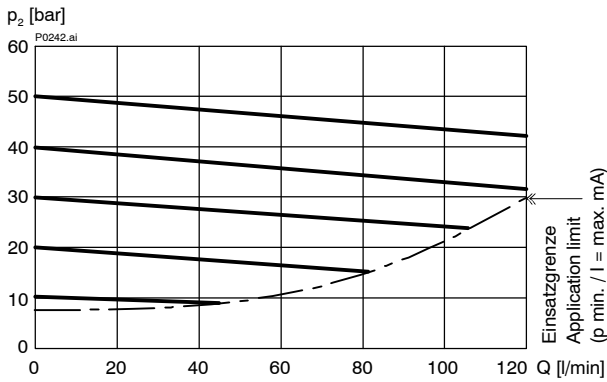

$p = f(Q)$  Pressure - Flow rate characteristic  $p_N = 100$  bar

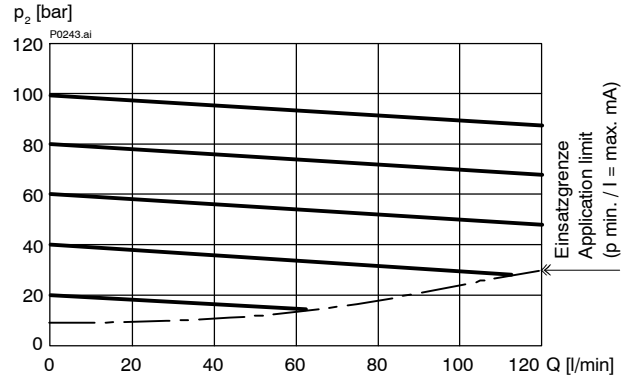

$p = f(Q)$  Pressure - Flow rate characteristic  $p_N = 160$  bar

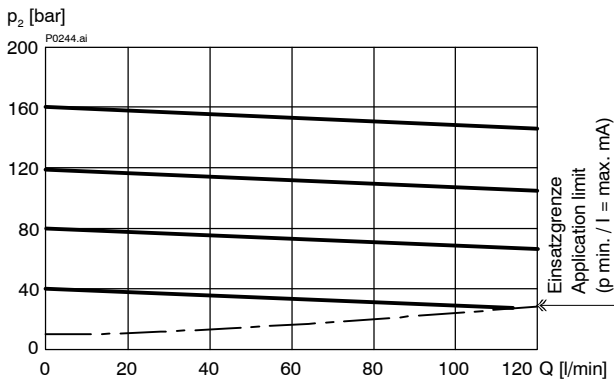

$p = f(Q)$  Pressure - Flow rate characteristic  $p_N = 230$  bar

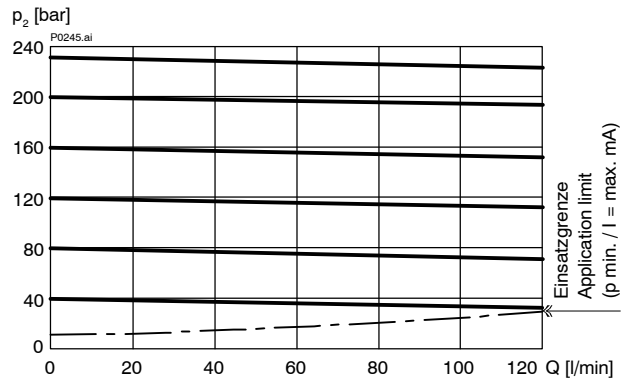

$p = f(Q)$  Pressure - Flow rate characteristic  $p_N = 300$  bar

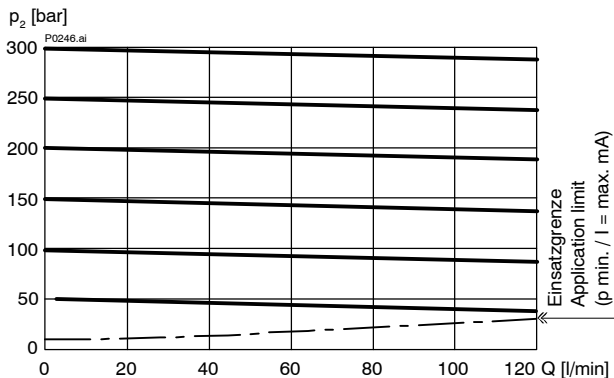

## 5 Dimensions & sectional view

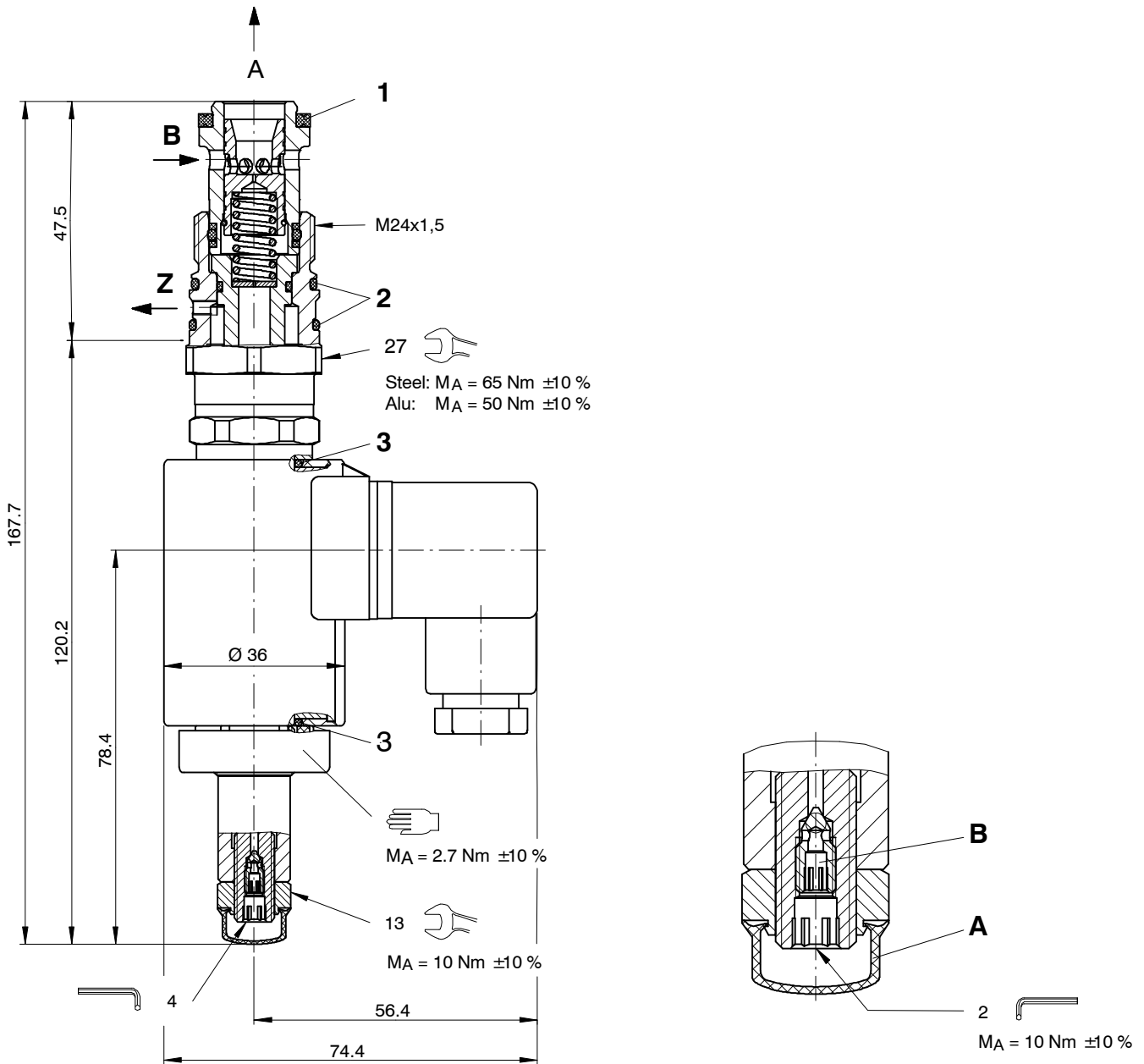

Seal kit NBR no. DS-339-N <sup>1)</sup>

Item	Qty.	Description
1	1	Seal ring Ø 22,10 / 16,50 x 2,50
2	2	O-ring no. 020 Ø 21,95 x 1,78 N90
3	2	O-ring Ø 16,00 x 2,00 Viton



### IMPORTANT!

<sup>1)</sup> Seal kit with FKM (Viton) seals no. DS-339-V

### Integral air-bleeding

If necessary, air can be purged from these proportional pressure-reducing cartridges by using the integral air-bleed screw (Item B). The procedure is as follows:

- A Protective cap
- B Air-bleed screw

Steps:

1. Remove the protective cap.
2. Slacken the air-bleed screw approx. 2 turns.
3. Switch the pressure-relief cartridge ON/OFF several times until no more air bubbles escape.
4. Tighten the air-bleed screw ( $M_a = 1 \text{ Nm} \pm 10\%$ ).
5. Fit the protective cap.

## 6 Installation information



### IMPORTANT!

To achieve the maximum performance rating, fit the solenoid coil as shown (with the plug pins at the bottom) and install the valve in a steel body. When fitting the cartridges, note the mounting attitude (preferably vertical, with coil down → automatic air bleed) and use the specified tightening torque. No adjustments are necessary, since the cartridges are set in the factory.



### ATTENTION!

Only qualified personnel with mechanical skills may carry out any maintenance work. Generally, the only work that should ever be undertaken is to check, and possibly replace, the seals. When changing seals, oil or grease the new seals thoroughly before fitting them.

## 7 Manual pressure setting

These inverse proportional pressure-reducing cartridges are equipped as standard with an integral manual pressure setting. If a proportional solenoid is faulty, for example, this manual pressure setting enables the required pressure to be set mechanically. The manual pressure setting can also be used to make minor pressure adjustments directly at the system.



### IMPORTANT!

Any changes to the manual pressure setting have a direct effect on the factory settings.

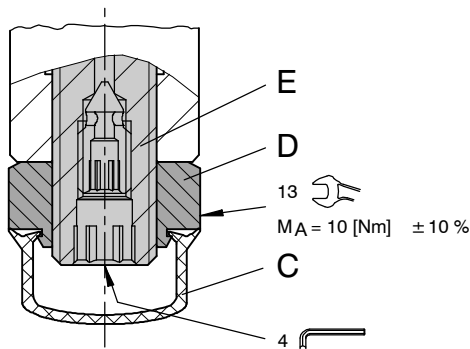

- C Protective cap
- D Lock nut (13 A/F)
- E Adjusting spindle for pressure setting

### Setting the pressure manually

Steps:

1. Remove the protective cap.
2. Slacken the lock nut (13 A/F).
3. Unscrew (turn to left) the adjusting spindle (4 A/F) until the required pressure is set.
4. Tighten the lock nut (13 A/F).
5. Fit the protective cap.



### ATTENTION!

To reset the inverse-proportional pressure-reducing cartridges to their initial position (the factory setting), a constant pressure ( $> p_N$ ) and a pressure gauge that measures the pressure in port A are needed. It should be noted that there must be no flow from B → A, and the set pressure must not exceed the nominal pressure of the spring range employed. The procedure is as follows:

### Restoring the factory settings

Steps:

1. Solenoid de-energised.
2. Remove the protective cap.
3. Slacken the lock nut (13 A/F).
4. Unscrew the adjusting spindle (4 A/F) to its end-stop, then screw it in until the pressure on the gauge reaches the nominal pressure ( $p_N$ ) of the spring range in use.
5. Tighten the lock nut (13 A/F).
6. Fit the protective cap.

### 8 Ordering code

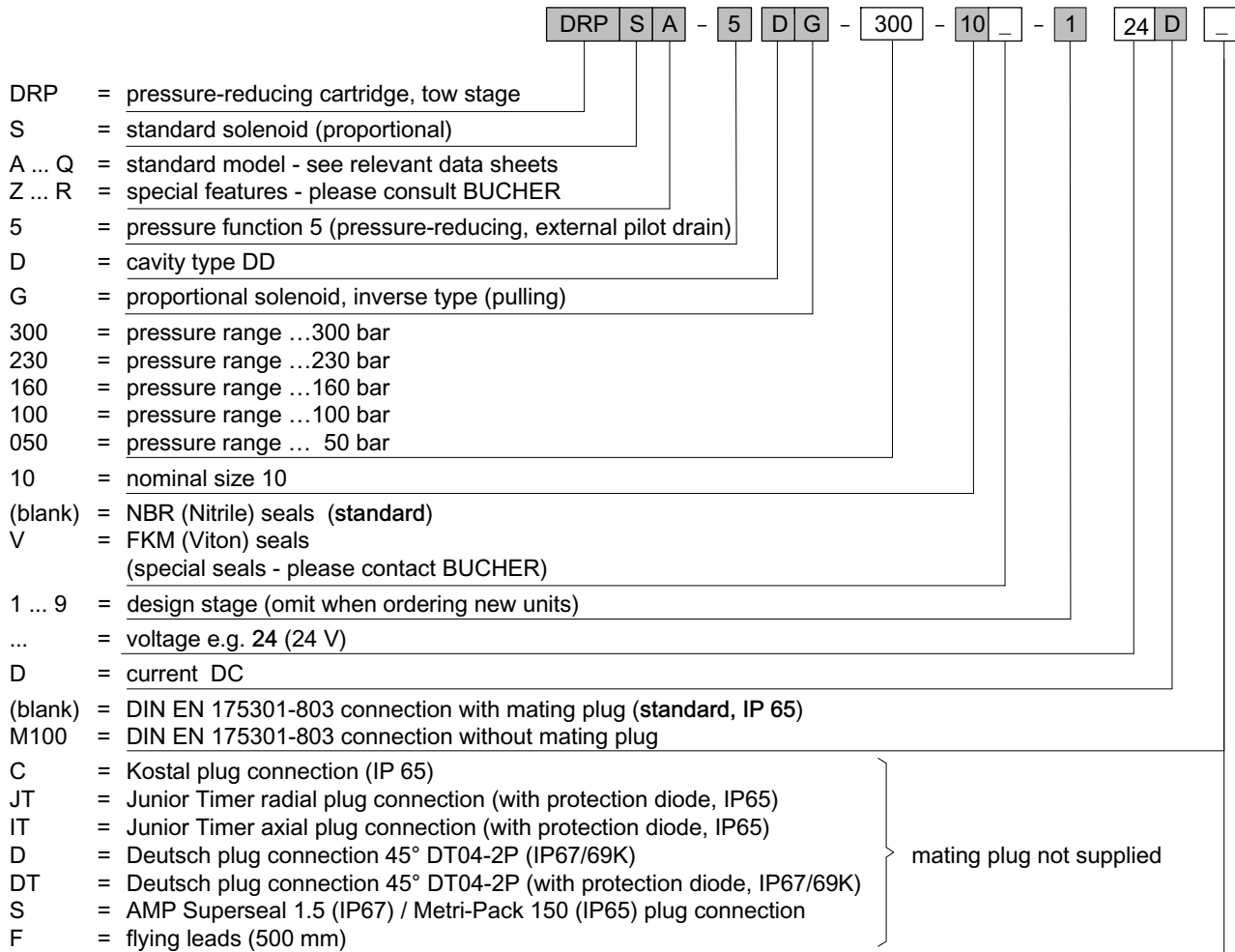

### 9 Related data sheets

Reference	(Old no.)	Description
400-P-040011	(i-32)	The form-tool hire programme
400-P-060121	(i-45.2)	Cavity type DD
400-P-120110	(W-2.141)	Coils for screw-in cartridge valves
400-P-510101		Amplifier unit for proportional valves (1-channel) PBS - 3A
400-P-740111	(G-24.21)	Line- and manifold-mounting body, type DDY-12 (G 1/2")

info.ch@bucherhydraulics.com

www.bucherhydraulics.com

© 2020 by Bucher Hydraulics AG Frutigen, CH-3714 Frutigen

All rights reserved.

Data is provided for the purpose of product description only, and must not be construed as warranted characteristics in the legal sense. The information does not relieve users from the duty of conducting their own evaluations and tests. Because the products are subject to continual improvement, we reserve the right to amend the product specifications contained in this catalogue.

Classification: 430.305.305.305.320.310